

EFR 6758-A

250 - 500 HP Turbo

EFR SERIES



Key Turbo Features

- Gamma-Ti turbine wheel
- Dual ceramic ball bearing assembly with metal cage
- Large internal wastegate
- Standard T25 mounting flange

Not Included with Turbo Assemblies:

- Speed sensor
- Turbine outlet V-Band
- Turbine inlet gasket
- Oil drain gasket or drain port fitting

COMPRESSOR MAP

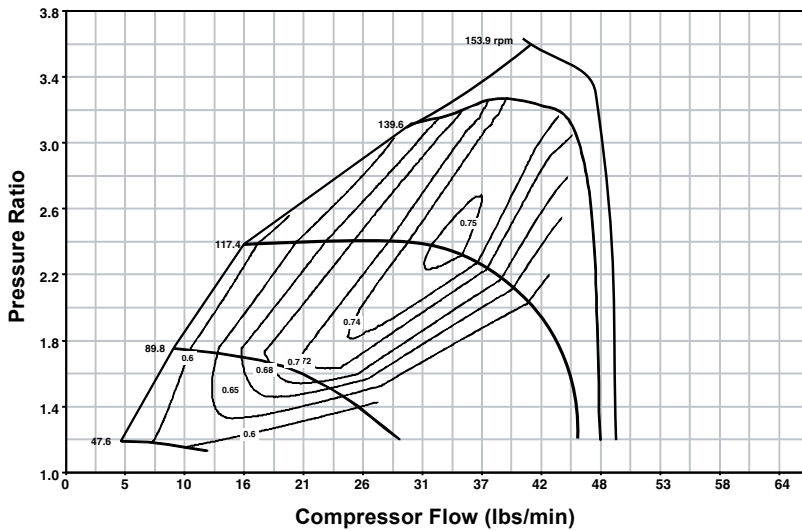

TURBINE HOUSING OPTIONS

Turbine Housing Part Number	A/R	Inlet Flange Shape	Housing Config
11581009006	0.64	T25	Single Scroll WG

Turbo Part #	Turbo Frame Size	Super Core Part #	Comp. Wheel Outer Dia. (mm)	Comp. Wheel Inducer Dia.	Turbine Wheel Outer Dia.	Turbo A/R	Inlet Flange Config
179388	B1	179375	67	54	58	.64	T25

TURBO FRAME DIMENSIONS

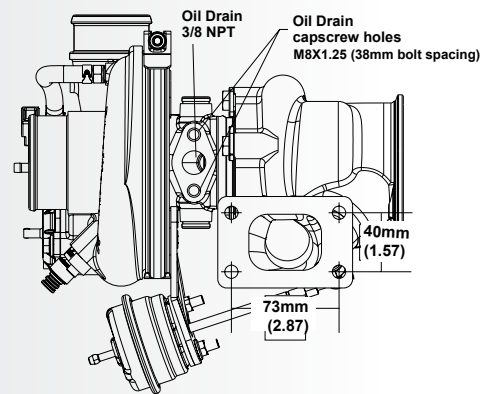
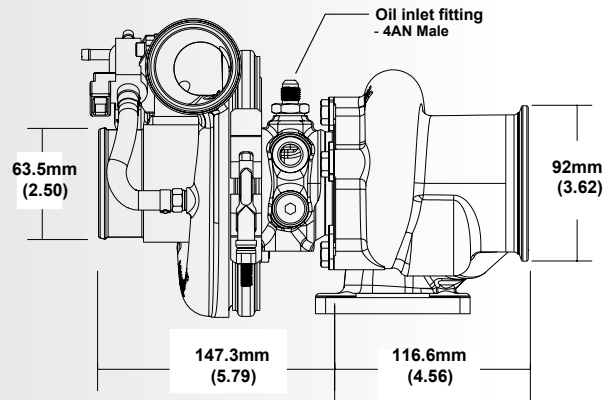
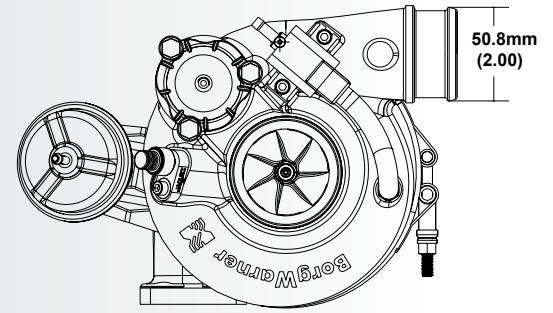

SUPER CORE CONFIGURATION

The following parts are not included as part of the super-core assembly: turbine housing, assembly clamp plate hardware, wastegate parts.