

EFR 8374-B

475 - 750 HP Turbo

EFR SERIES



Key Turbo Features

- Gamma-Ti turbine wheel
- Dual ceramic ball bearing assembly with metal cage
- Large internal wastegate
- Standard T3 mounting flange

Not Included with Turbo Assemblies:

- Speed sensor
- Turbine outlet V-Band
- Turbine inlet gasket
- Oil drain gasket or drain port fitting

COMPRESSOR MAP

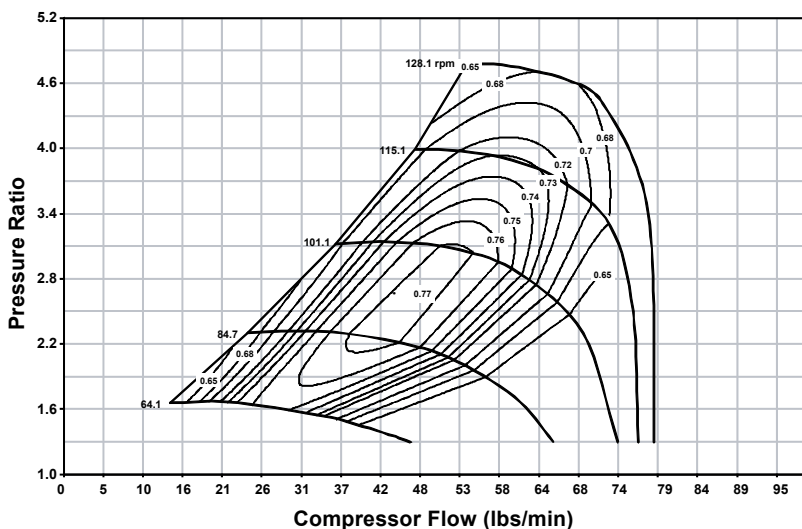

TURBINE HOUSING OPTIONS

Turbine Housing Part Number	A/R	Inlet Flange Shape	Housing Config
12741008000	0.83	T3	Single Scroll WG
12741008001	0.92	T4	Twin Scroll WG
12741019002	1.05	T4	Twin Scroll Non WG
12741008003	1.45	T4	Twin Scroll Non WG

Turbo Part #	Turbo Frame Size	Super Core Part #	Comp. Wheel Outer Dia. (mm)	Comp. Wheel Inducer Dia.	Turbine Wheel Outer Dia.	Turbo A/R	Inlet Flange Config
179258	B2	179257	83	62	74	.83	T3

TURBO FRAME DIMENSIONS

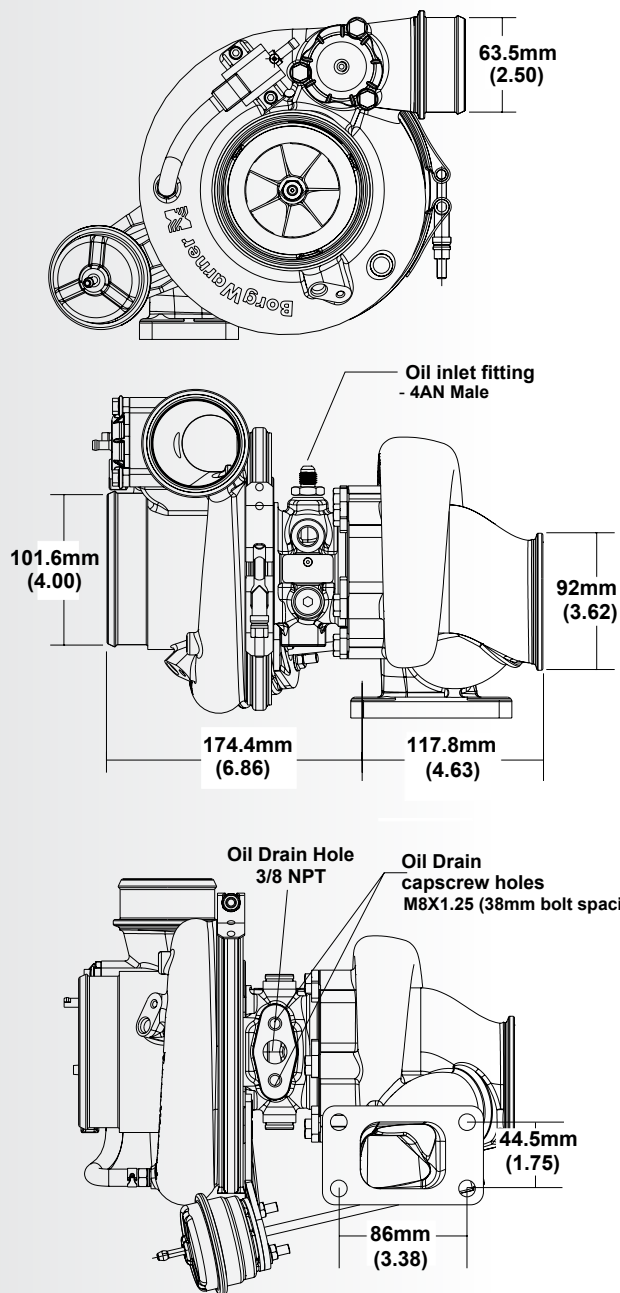

SUPER CORE CONFIGURATION

The following parts are not included as part of the super-core assembly: turbine housing, assembly clamp plate hardware, wastegate parts.